

Technische Daten: Art.-Nr.: 871020

Wandaußenmaß: 530 x 530 cm

Bohlenstärke: 70 mm



Durch Kunden farblich endbehandelt

Kontrolliert durch:

Achtung: Alle angegebenen Maße sind ca.-Maße!

3D-Darstellung und Grundriss 871020

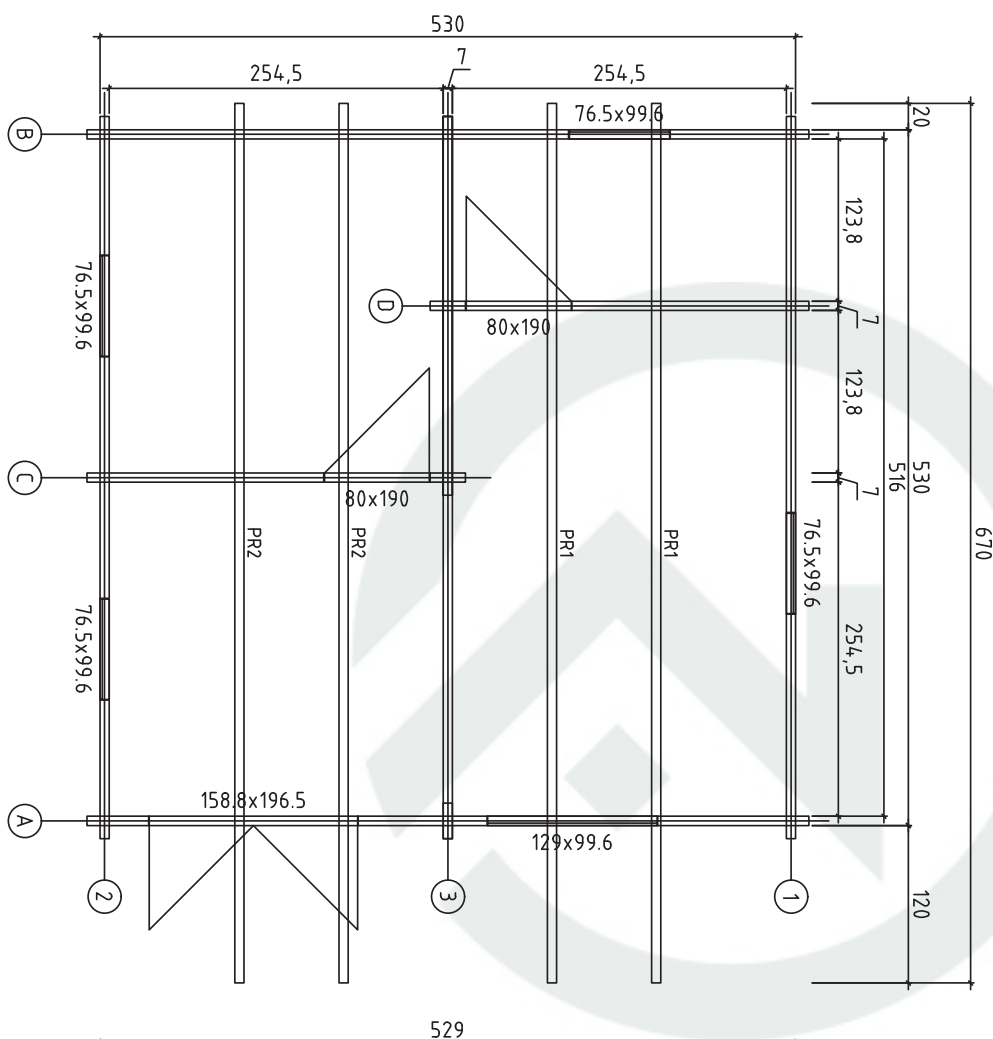
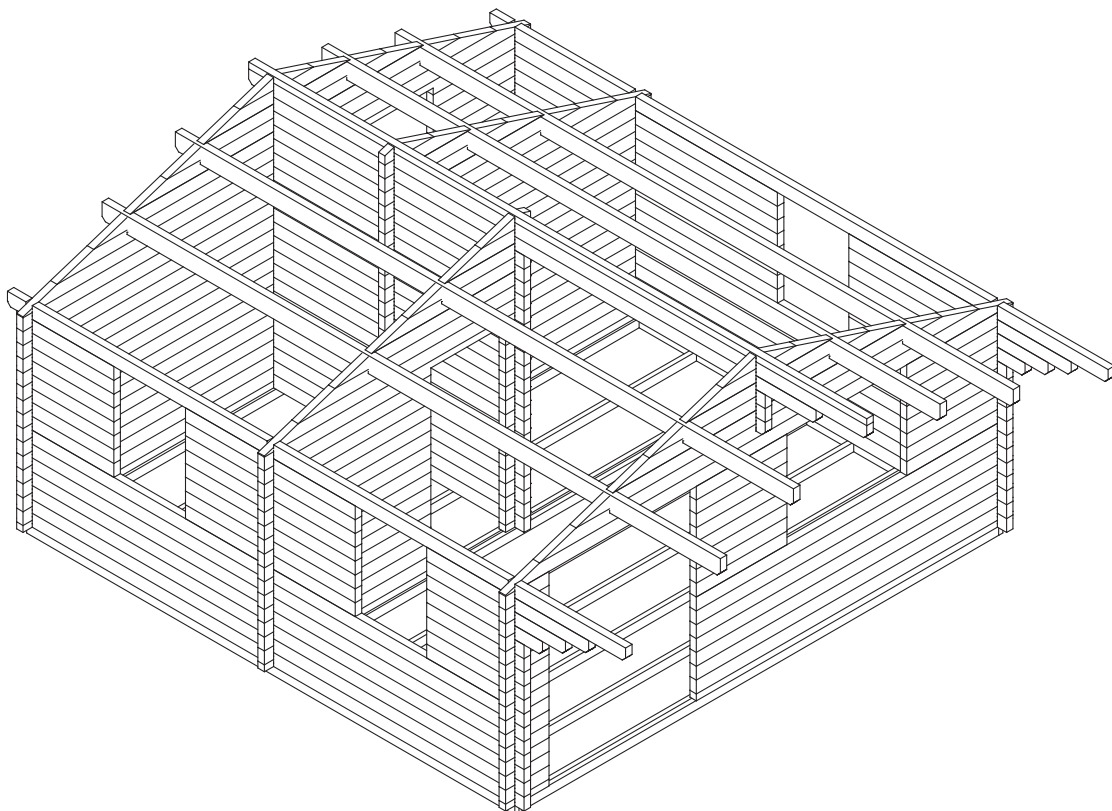

Lagerholzplan und Fundamentplan 871020

Wir empfehlen als Fundament für Ihr Gartenhaus eine vollflächig,
festgegründete gepflasterte oder betonierte Fläche.
Wahlweise ist auch ein Punkt- oder Streifenfundament möglich.

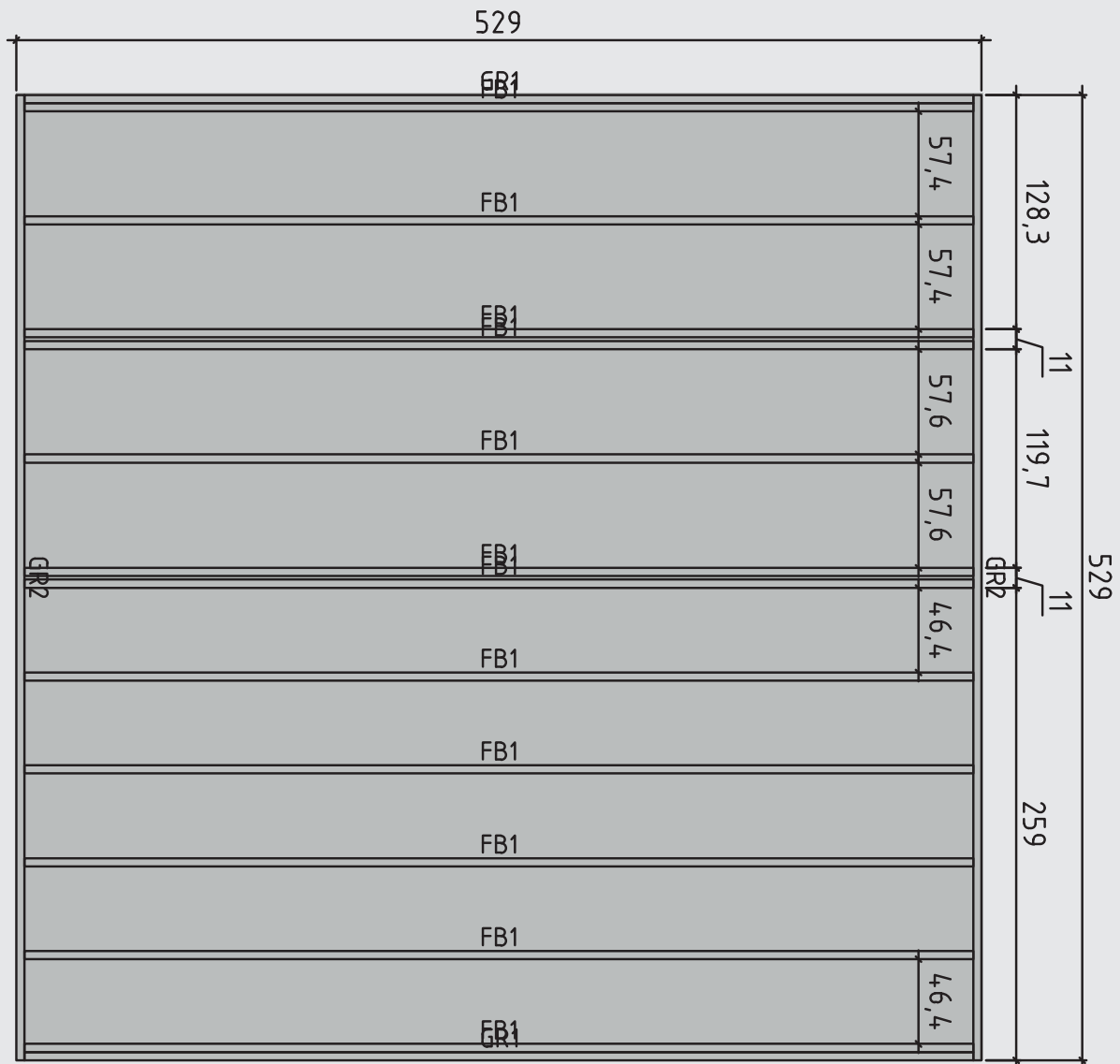









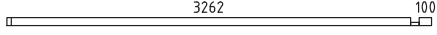

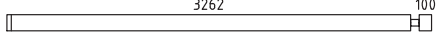
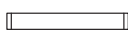
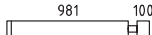
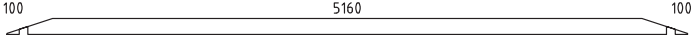
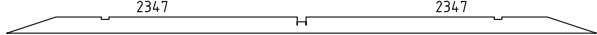
Teileliste 1

871020

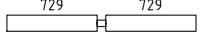
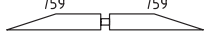
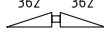
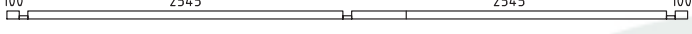
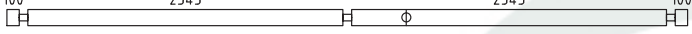
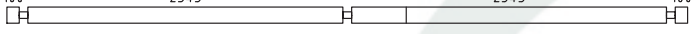
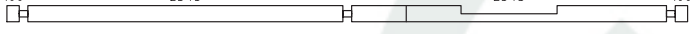

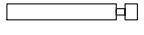
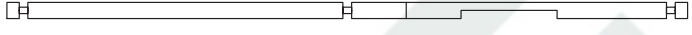
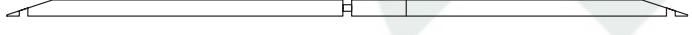

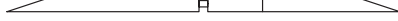

Pos			Profil (mm)	Lenght (mm)
001		1	70x130	5500
002		1	70x130	5500
003		5	70x130	5500
004		8	70x130	3016
005		5	70x130	1709
006		1	70x130	1909
007		1	70x130	2159
008		1	70x130	2409
009		1	70x130	6700
010		1	70x130	5500
011		1	70x130	5500
012		5	70x130	5500
013		13	70x130	1055
014		8	70x130	1840
015		1	70x130	1255
016		1	70x130	1505
017		1	70x130	1755
018		1	70x130	6700
019		1	70x130	2885
020		19	70x130	2885
021		1	70x130	270
022		30	70x130	270
023		1	70x130	6050
024		1	70x130	6700
025		1	70x65	6700

Teilleiste 2 871020

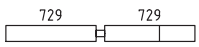
Pos			Profil (mm)	Lenght (mm)
026		1	70x65	470
027		1	70x65	3432
028		15	70x130	470
029		7	70x130	3432
030		8	70x130	981
031		8	70x130	1151
032		1	70x130	5500
033		1	70x130	4763
034		12	70x120	367
035		1	70x130	3115
036		1	70x130	3175
037		1	70x130	1528
038		1	70x130	1588
039		2	70x119	794
040		1	70x65	5500
041		1	70x130	5500
042		5	70x130	5500
043		1	70x130	5500
044		7	70x130	3670
045		7	70x130	1055
046		1	70x130	5500
047		1	70x130	5500
048		1	70x130	4763
049		1	70x130	3115
050		1	70x130	3175

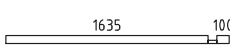

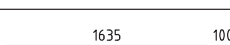
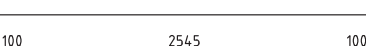
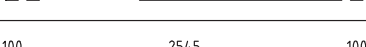
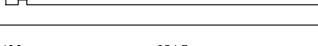
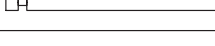
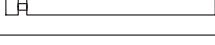
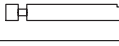
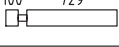

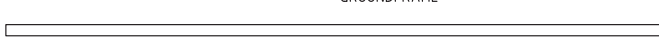
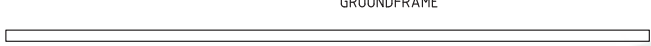
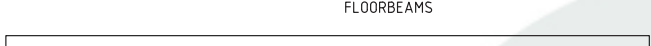
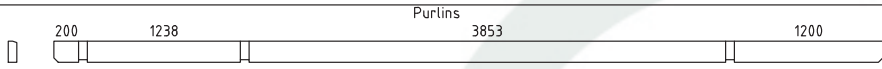
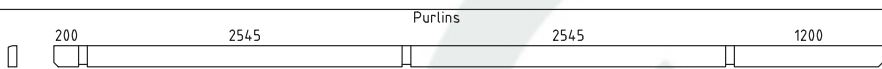





Teileliste 3

871020

Pos			Profil (mm)	Lenght (mm)
051		1	70x130	1528
052		1	70x130	1588
053		2	70x65	1805
054		2	70x65	270
055		28	70x130	1805
056		2	70x130	2885
057		2	70x130	2885
058		2	70x130	2517
059		2	70x130	1693
060		2	70x130	1723
061		2	70x130	899
062		2	70x130	929
063		2	70x119	532
GR2	GROUNDFRAME 	2	45x90	5290
GR1	GROUNDFRAME 	2	45x90	5200
FB1	FLOORBEAMS 	12	45x90	5200
PR1	Purlins 	2	70x170	6700
PR2	Purlins 	2	70x170	6700
	WINDOW 1290x996	1		
	WINDOW 765x996	4		
	DOOR 1588x1965	1		
	DOOR 800x1900	2		

















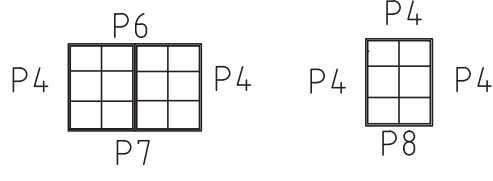
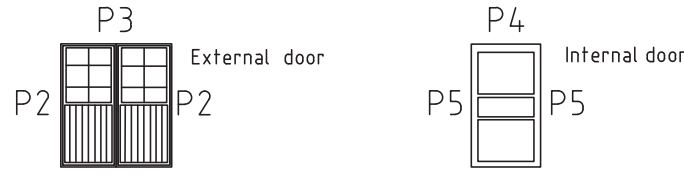

Teilleiste 4

871020

Pos			Profil (mm)	Lenght (mm)
1	Screws/Schrauben/Vis 5x100 mm- For fixing first row of wall logs /Fixierung des ersten Bohlenkranzes/Pour fixer les lames de plancher		6	
2	Nails/Nägél/Clous 2.1x50 - For fixing floorboards/ Befestigung Fussbodenbretter/Pour fixer les lames de plancher		495	
3	Nails/Nägél/Clous 2.1x50 - For fixing roofboards/ Befestigung Dachbretter/Pour fixer les voliges		550	
4	Nails/Nägél/Clous 2.1x50 - For fixing floor edge trims/ Befestigung Fussleisten/Pour fixer les plinthes du plancher		30	
5	Nails/Nägél/Clous 2.1x50 - For fixing roofing felt fillet/ Befestigung giebelabschlussbrett/Pour fixer la latte de finition de la couverture		20	
6	Screws/Schrauben/Vis 3,5x50 mm- For fixing roof side boards and roof edge reinforcement Befestigung Traufenbretter und Traufenleisten Pour fixer les planches de rive et le tasseau de refront		44	
7	Screws/Schrauben/Vis 3,5x50 mm- For fixing fascia boards and diamonds/ Befestigung Giebelblende und Raute Pour fixer les planches de rive et le diamant		28	
8	Screws/Schrauben/Vis 3,5x50 mm- For fixing fwindow and door trims/ Befestigung Fenster und Türen/ Pour fixer les croisillons des fenetres et des portes		68	
9	Metal storm Brace/Gewindestange/Tige filetée 10 mm		5	
10	Shim,Nuts/Mutter ,U-Scheibe/Ecrou,Rondelle 10 mm For fixing storm braces/ Pour fixer les anti tempete/ Für Sturmleisten Pour fixer les croisillons des fenetres et des portes Metal storm Brace/Gewindestange/Tige filetée 10 mm KL1 M10 2,18 m 4 Screws 180 10pcs. KL2 M10 2,89 m 1 Plastic caps 5 pcs.		5/5	

Teileliste 5

871020

POS	ST.	B	H	L	ERKLÄRUNG	
FB1	Vt. spetsi					FLOORBEAMS
F1	13,12m ²	28		2540		FUSSBODENBRETTER 59/45/37
F2	9,8m ²	28		3847		FUSSBODENBRETTER 30/23/19
F3	3,15m ²	28		1233		FUSSBODENBRETTER 30/23/19
PR	4	70	170	6700		ROOFBEAMS
RB1	40,89m ²	20		3052		Dachbretter 154/118/98
R1	4	20	120	3350	<i>Vaata katuse kaldenurka</i> 	Frontboard
R2	4	45	65	3350	<i>Vaata katuse kaldenurka</i> 	Frontboard fixing board
R3	4	20	120	3300	<i>Vaata katuse kaldenurka</i> 	Girders facade
R4	4	20	90	3300		Topboard
WN29 WN07	1 4	1290 765	996 996			Sliding slats 30x30x1900 mm - 2 pcs. 30x30x900 mm - 2 pcs.
DR15 DR08	1 2	1588 800	1965 1900			External door Internal door
P1	38m	20	40			Floor edge trim
P2	2+2	20	90	1945		Fixing boards for DR15
P3	1+1	20	90	1890		Fixing boards for DR15
P4	32	20	90	1100		Fixing boards for DR08, WN29, WN07
P5	4+4	20	90	1880		Fixing boards for DR08
P6	1+1	20	90	1590		Fixing boards for WN29
P7	1+1	20	90	1250		Fixing boards for WN29
P8	4+4	20	90	725		Fixing boards for WN07

Detailzeichnungen 871020

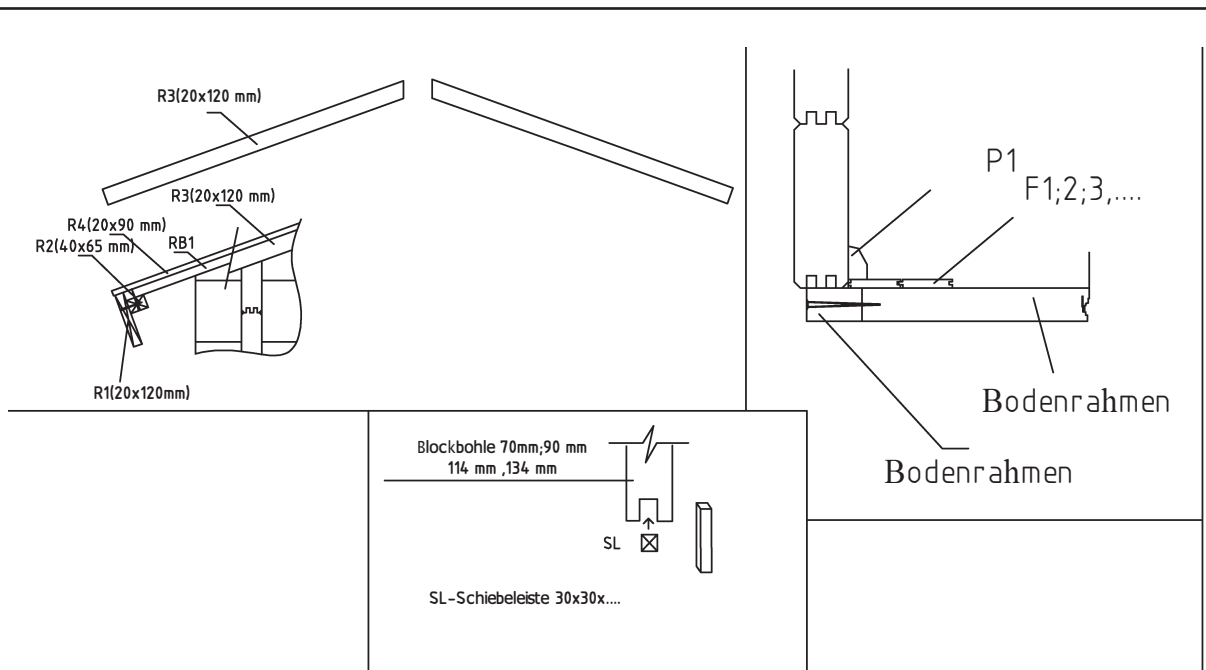

Dichtungssystem der Blockbohlen

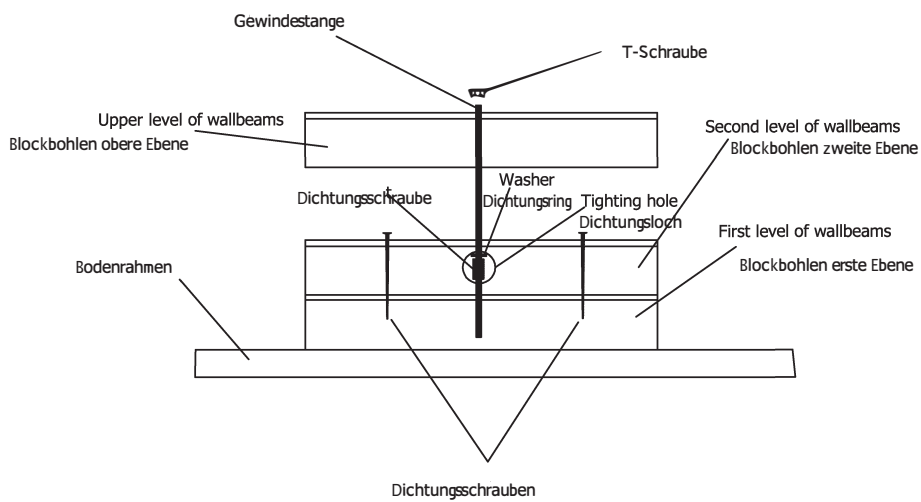

Wandplan 1 und 2 871020

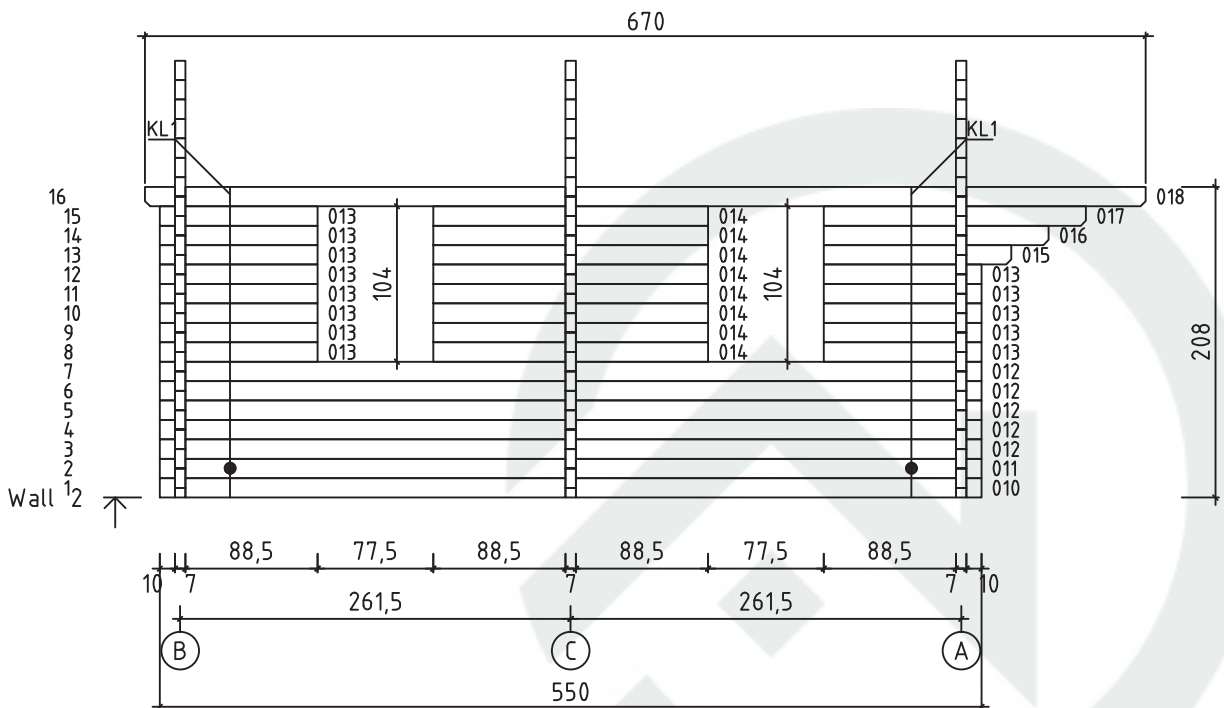
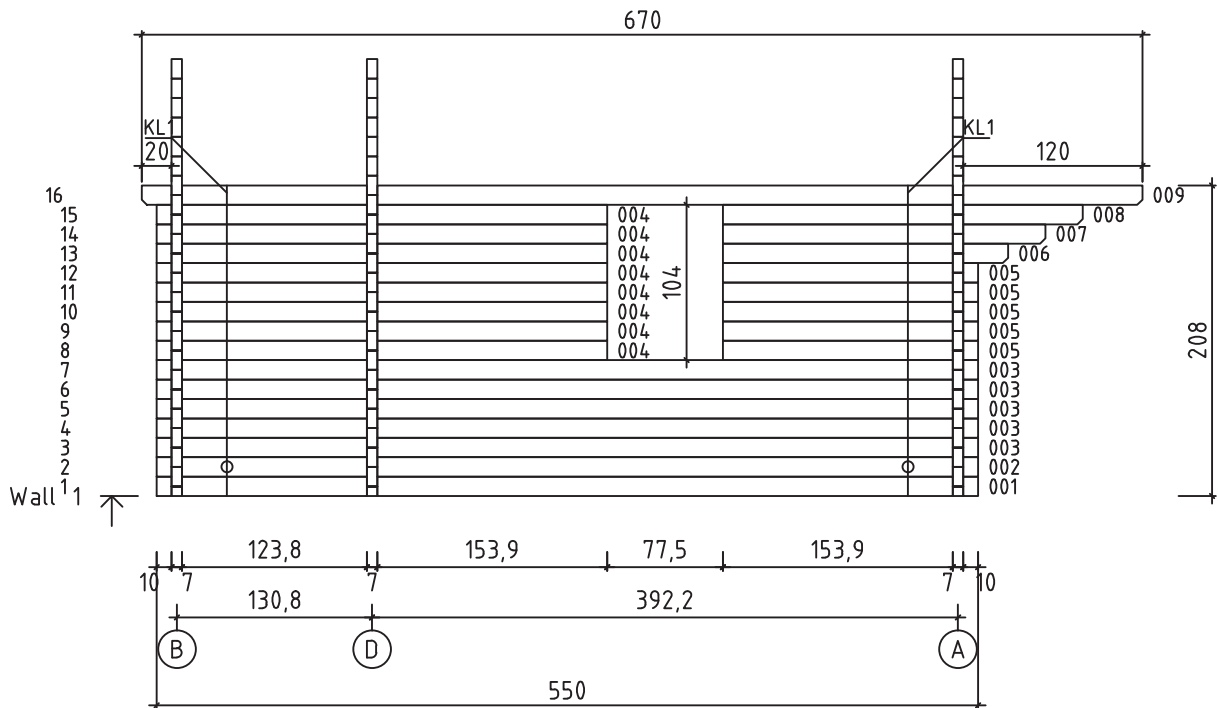

Wandplan 3 871020

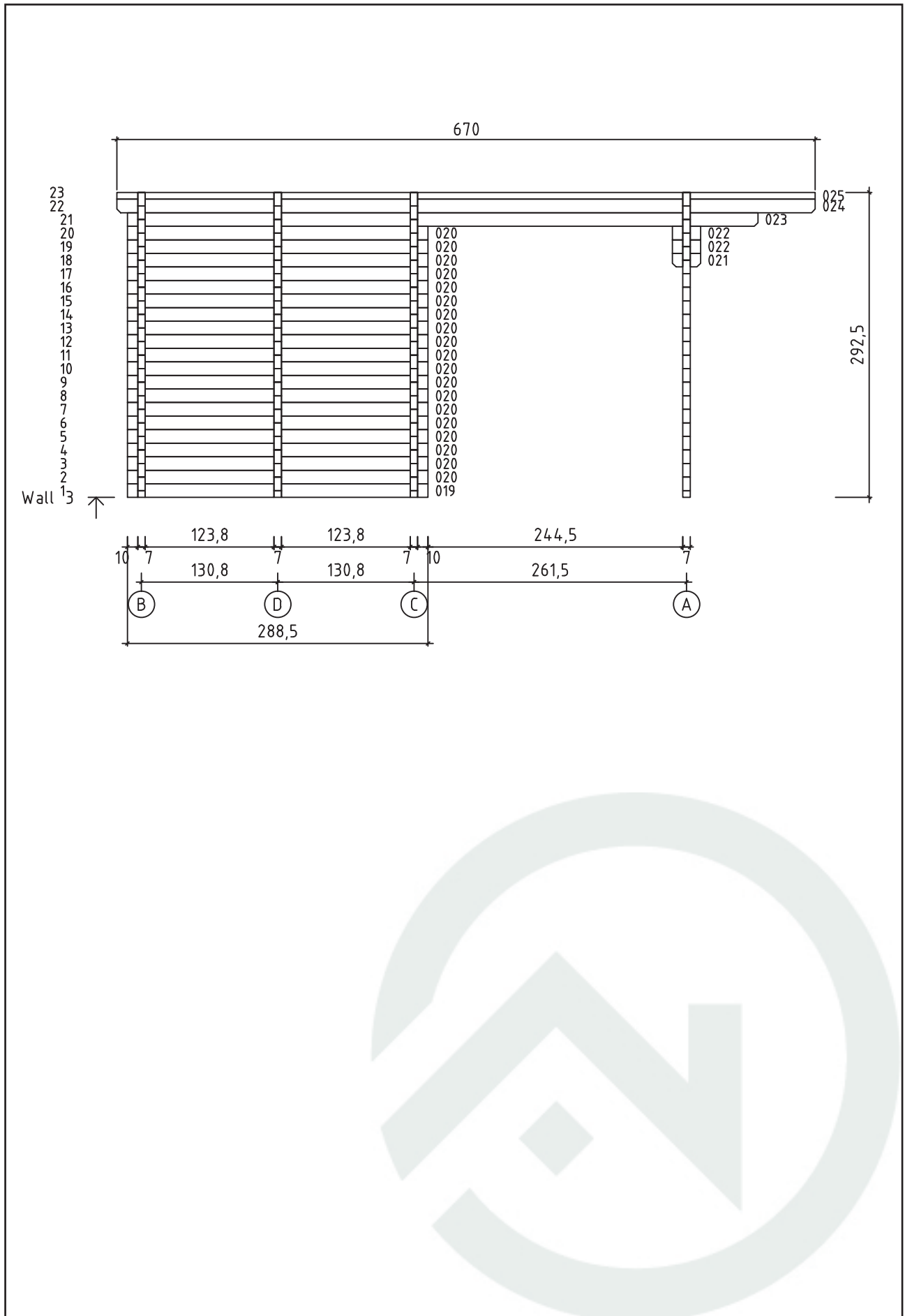

Wandplan A und B 871020

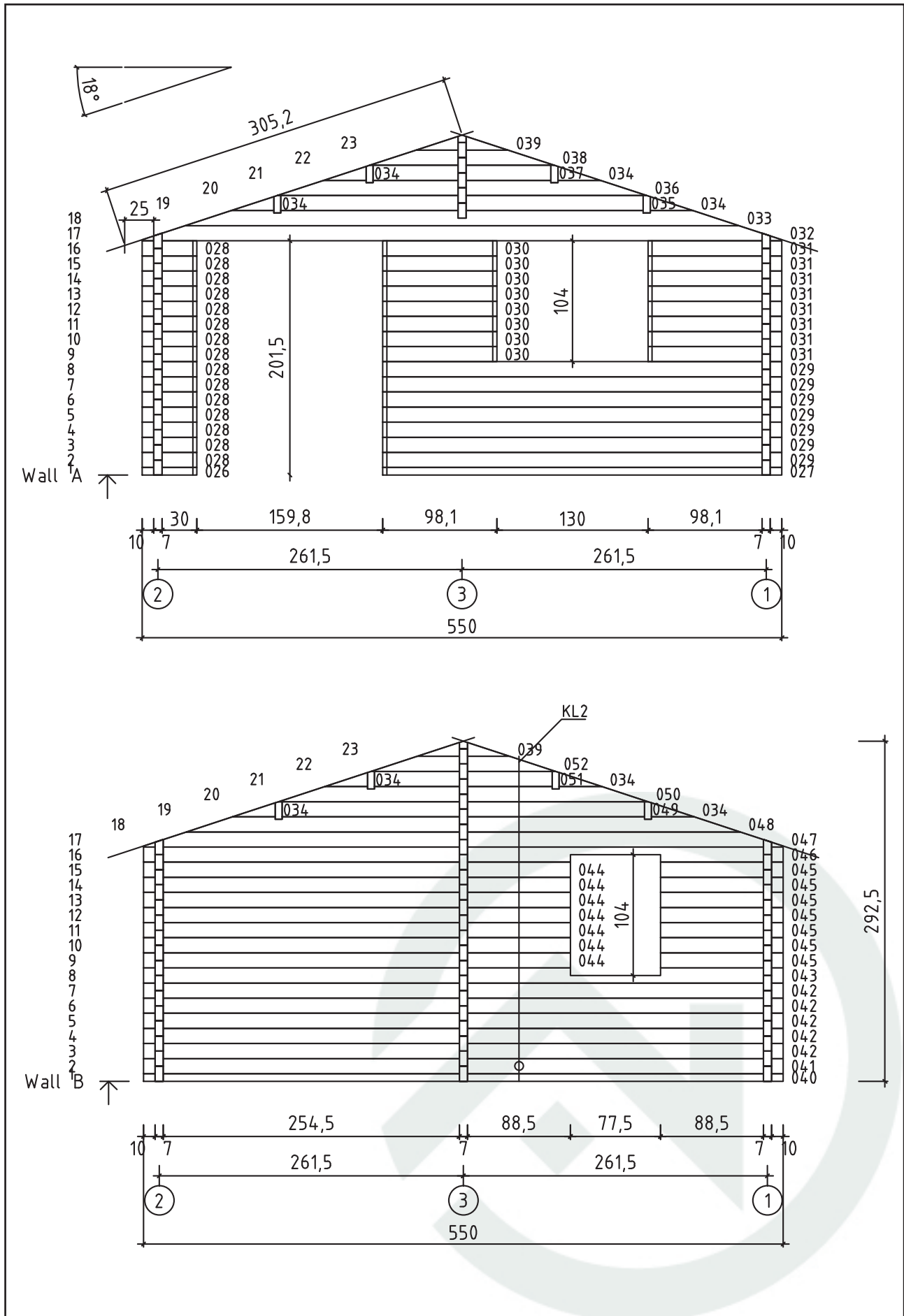

Wandplan C und D 871020

