

# Technische Daten: Art.-Nr.: 871110

Wandaußenmaß: 500 x 500 cm

Bohlenstärke: 70 mm



Lapland 70-B, durch Kunden farblich endbehandelt

Kontrolliert durch:

Empty box for signature or name.

Achtung: Alle angegebenen Maße sind ca.-Maße!

# 3D-Darstellung und Grundriss 871110

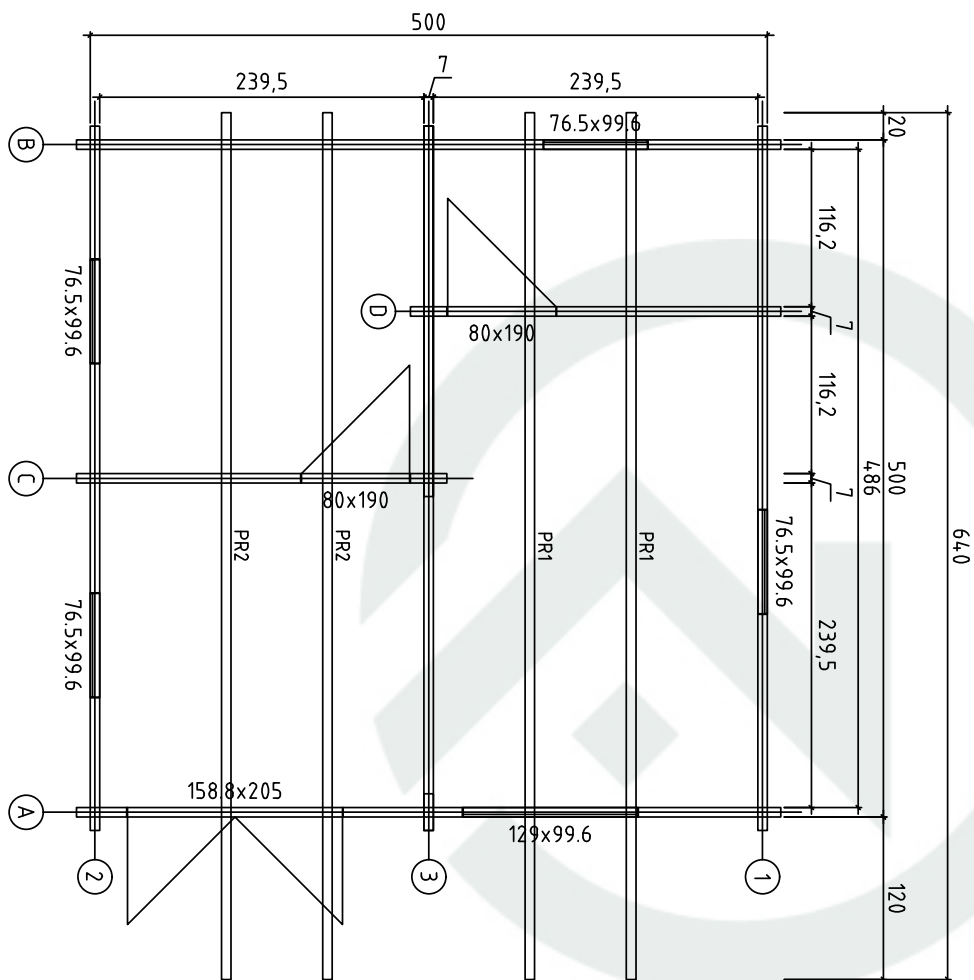
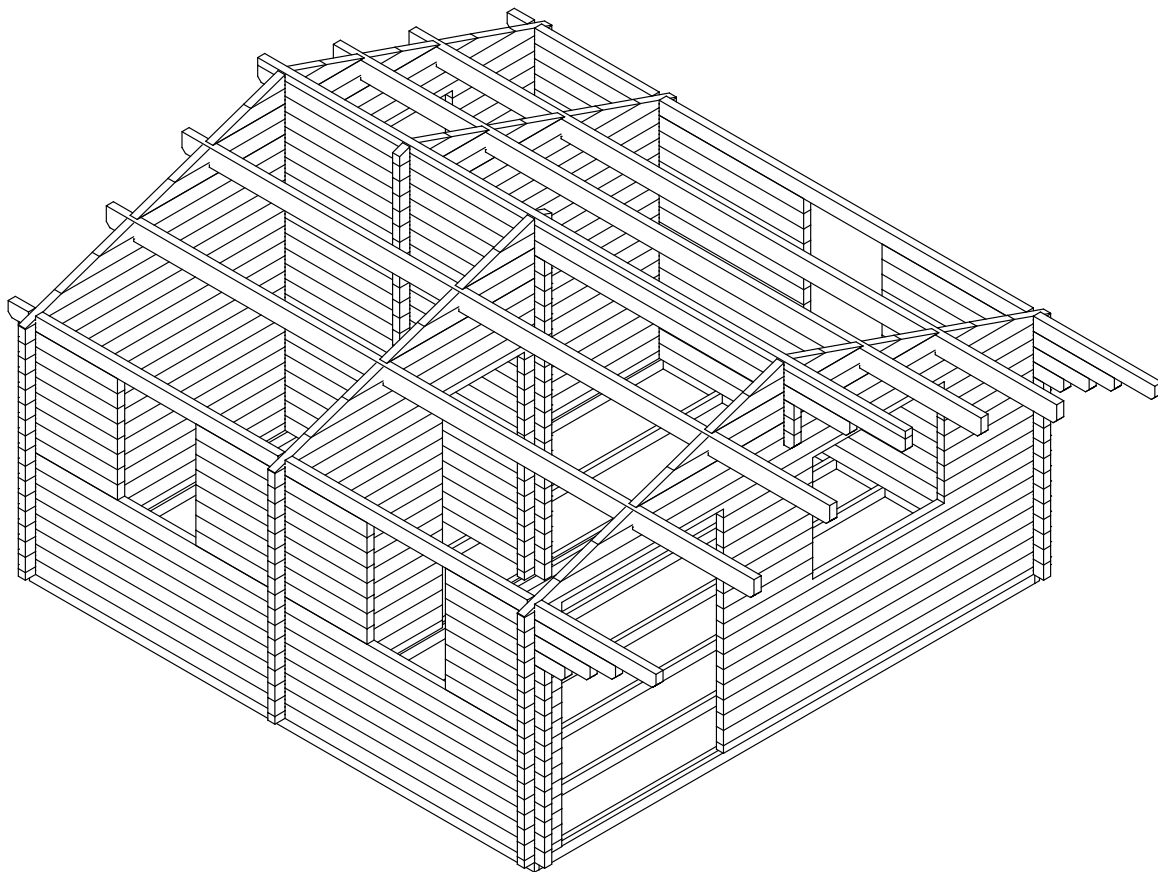

# Lagerholzplan und Fundamentplan 871110

Wir empfehlen als Fundament für Ihr Gartenhaus eine vollflächig festgegründete, gepflasterte oder betonierte Fläche.  
Wahlweise ist auch ein Punkt- oder Streifenfundament möglich.

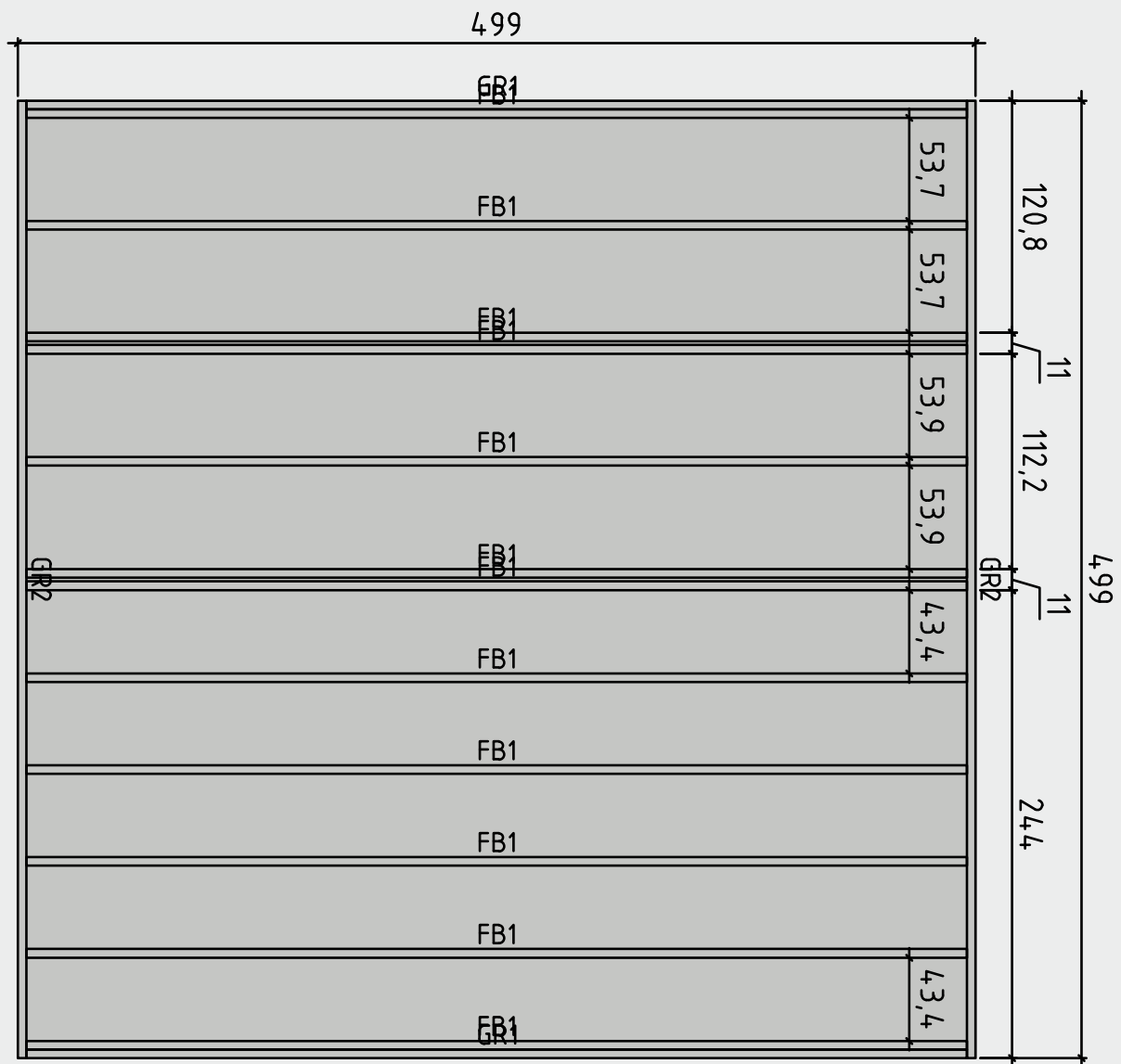





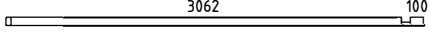

# Teileliste 1

## 871110

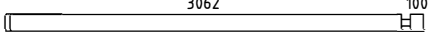
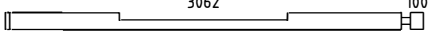
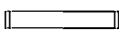
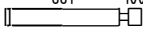
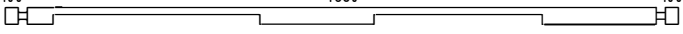
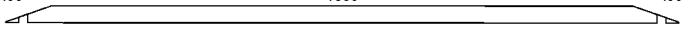
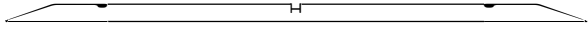
Pos			Profil (mm)	Lenght (mm)
001		1	70x130	5200
002		1	70x130	5200
003		6	70x130	5200
004		8	70x130	2829
005		5	70x130	1596
006		1	70x130	1796
007		1	70x130	2046
008		1	70x130	2296
009		1	70x130	6400
010		1	70x130	5200
011		1	70x130	5200
012		6	70x130	5200
013		13	70x130	980
014		8	70x130	1690
015		1	70x130	1180
016		1	70x130	1430
017		1	70x130	1680
018		1	70x130	6400
019		1	70x130	2735
020		20	70x130	2735
021		1	70x130	270
022		30	70x130	270
023		1	70x130	5750
024		1	70x130	6400
025		1	70x65	6400

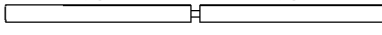
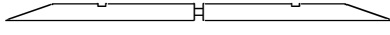
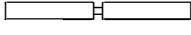
# Teilleiste 2 871110

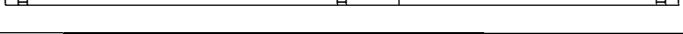
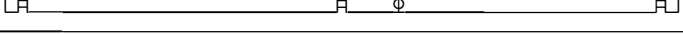
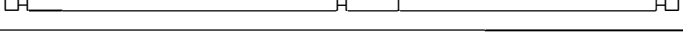
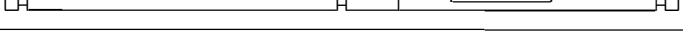
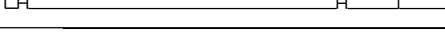
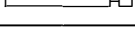
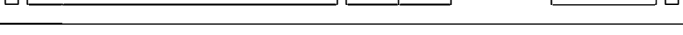
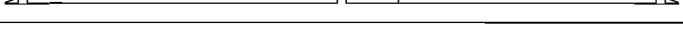
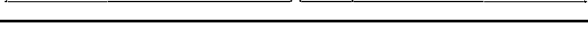
Pos			Profil (mm)	Lenght (mm)
026		1	70x65	370
027		1	70x65	3232
028		15	70x130	370
029		7	70x130	3232
030		1	70x130	3232
031		7	70x130	881
032		7	70x130	1051
033		1	70x130	5200
034		1	70x130	5200
035		1	70x130	4486
036		12	70x120	344
037		1	70x130	2931
038		1	70x130	2991
039		1	70x130	1435
040		1	70x130	1495
041		2	70x118	748
042		1	70x65	5200
043		1	70x130	5200
044		6	70x130	5200
045		1	70x130	5200
046		7	70x130	3445
047		7	70x130	980
048		1	70x130	5200
049		1	70x130	5200
050		1	70x130	4486

















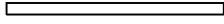

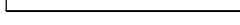

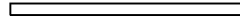

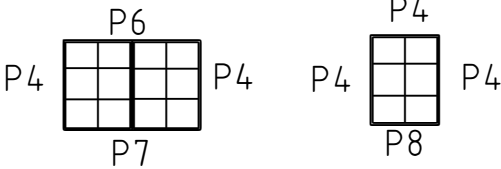
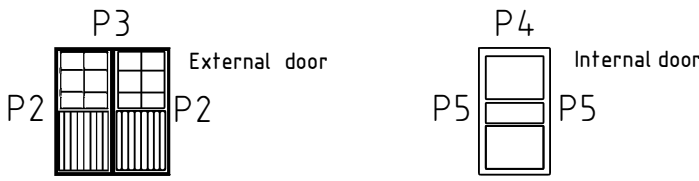

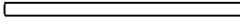

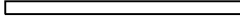
# Teilleiste 3 871110

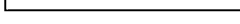
Pos			Profil (mm)	Lenght (mm)
051		1	70x130	2931
052		1	70x130	2991
053		1	70x130	1435
054		1	70x130	1495
055		2	70x65	1655
056		2	70x65	270
057		28	70x130	1655
058		2	70x130	2735
059		2	70x130	2735
060		2	70x130	2735
061		2	70x130	2378
062		2	70x130	1600
063		2	70x130	1630
064		2	70x130	853
065		2	70x130	883
066		2	70x118	509
GR2	GROUNDFRAME 	2	45x90	4990
GR1	GROUNDFRAME 	2	45x90	4900
FB1	FLOORBEAMS 	12	45x90	4900
PR1	Purlins 	2	70x170	6400
PR2	Purlins 	2	70x170	6400
	WINDOW 1290x996	1		
	WINDOW 765x996	4		
	DOOR 1588x2050	1		
	DOOR 800x1900	2		

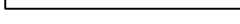

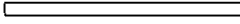
# Teileliste 5

## 871110

POS	ST.	B	H	L	ERKLÄRUNG	
FB1	Vt. spetsi					FLOORBEAMS
F1	11,5m <sup>2</sup>	28		2390		FUSSBODENBRETTER 56/43/35
F2	8,68m <sup>2</sup>	28		3623		FUSSBODENBRETTER 28/21/18
F3	2,78m <sup>2</sup>	28		1157		FUSSBODENBRETTER 28/21/18
PR	4	70	170	6400		ROOFBEAMS
RB1	37,3m <sup>2</sup>	20		2912		Dachbretter 148/113/93
R1	4	20	120	3200		Frontboard 
R2	4	45	65	3200		Frontboard fixing board 
R3	4	20	120	3150		Girders facade 
R4	4	20	90	3150		Topboard 
WN29 WN07	1 4	1290 765	996 996		 <p>Sliding slats 30x30x1900 mm - 2 pcs. 30x30x800 mm - 2 pcs.</p>	
DR15 DR08	1 2	1588 800	2050 1900		 <p>External door Internal door</p>	
P1	35m	20	40			Floor edge trim
P2	2+2	20	90	2030		Fixing boards for DR15 
P3	1+1	20	90	1890		Fixing boards for DR15 
P4	32	20	90	1100		Fixing boards for DR08, WN29, WN07 
P5	4+4	20	90	1880		Fixing boards for DR08 
P6	1+1	20	90	1590		Fixing boards for WN29 
P7	1+1	20	90	1250		Fixing boards for WN29 
P8	4+4	20	90	725		Fixing boards for WN07 



# Detailzeichnungen 871110

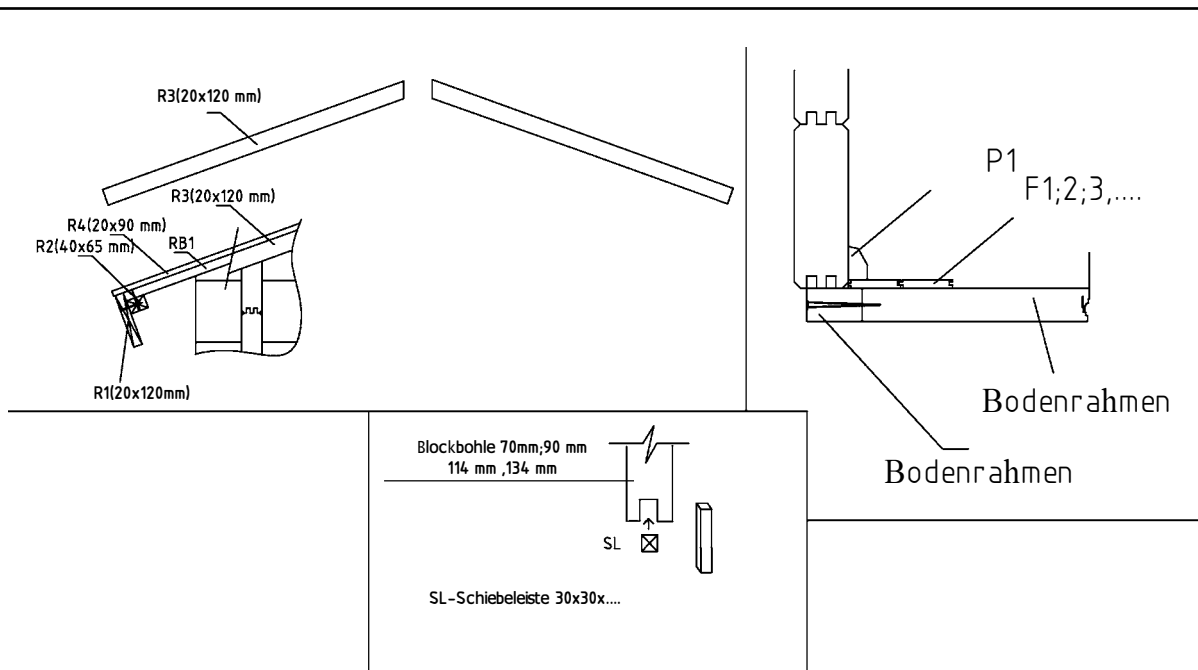

## Dichtungssystem der Blockbohlen

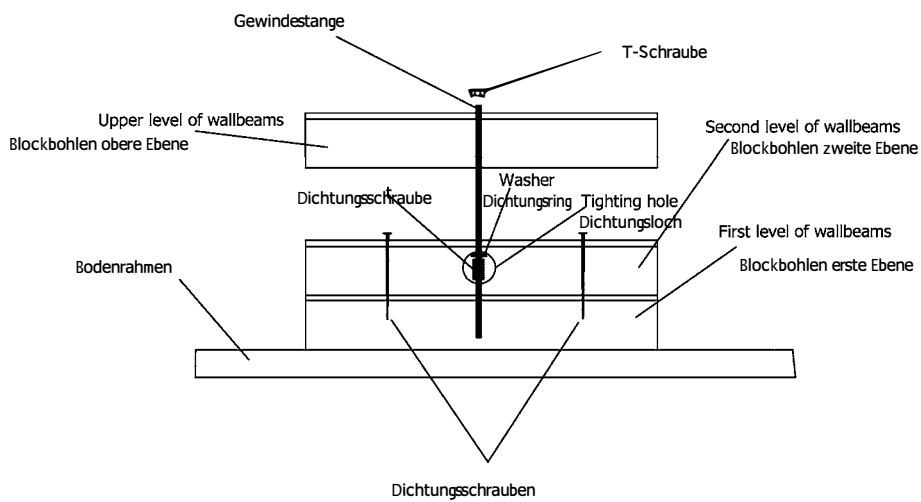

# Wandplan 1 und 2 871110

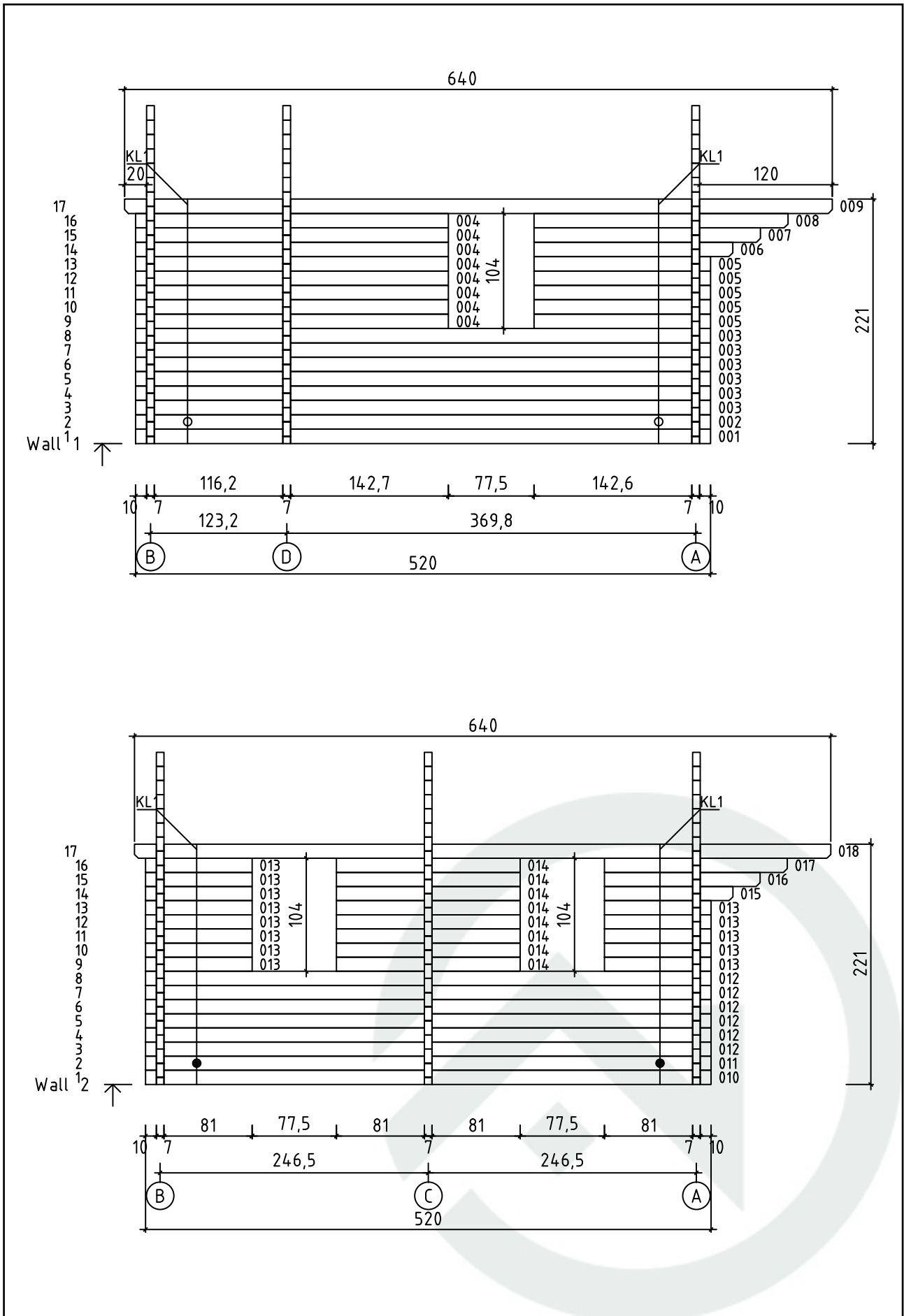

# Wandplan 3 871110

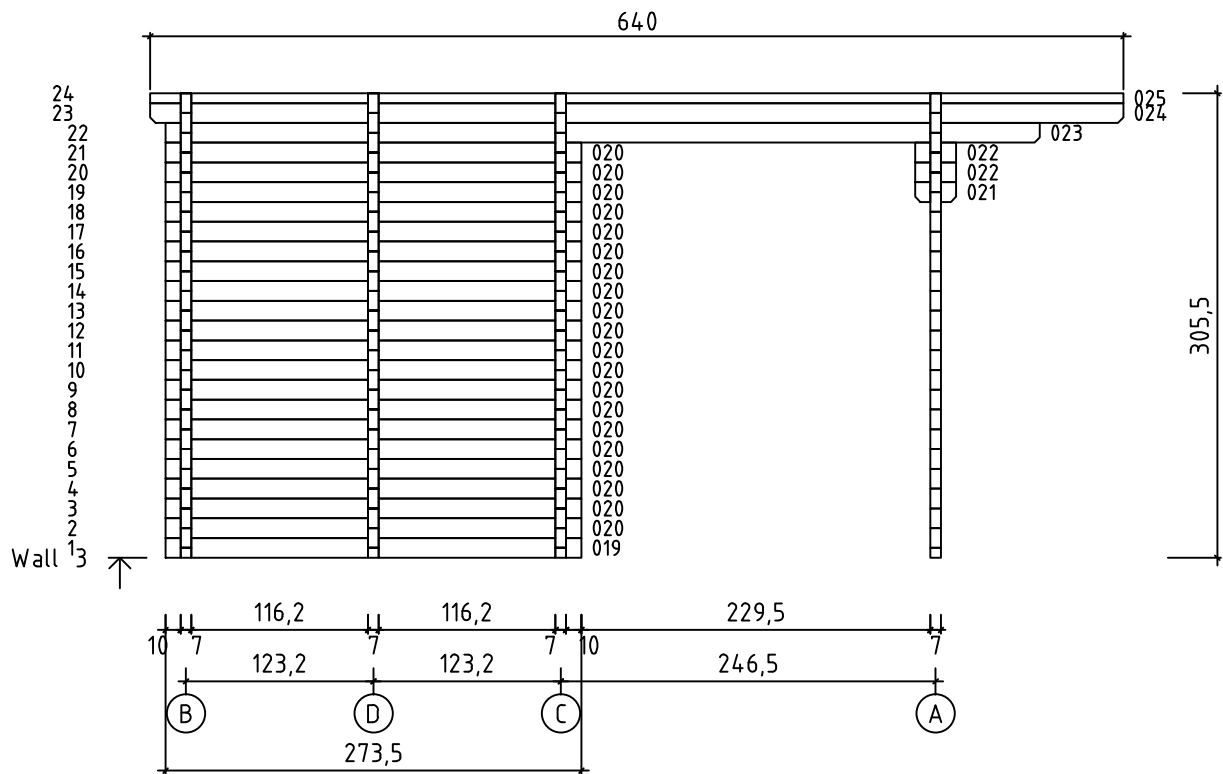

# Wandplan A und B 871110

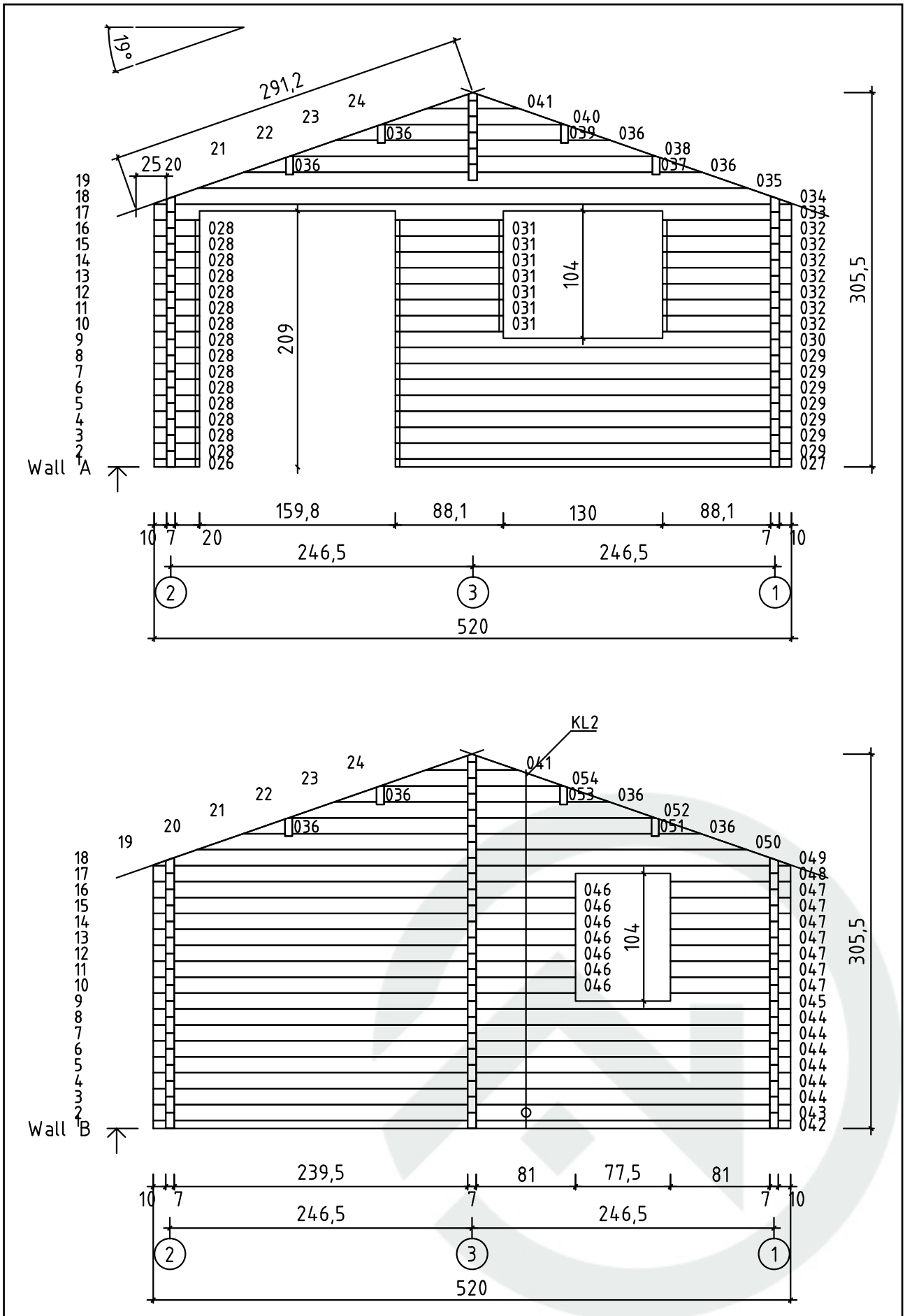

# Wandplan C und D 871110

